

# COONEY SMART COIL

## Installation and Operation Guide

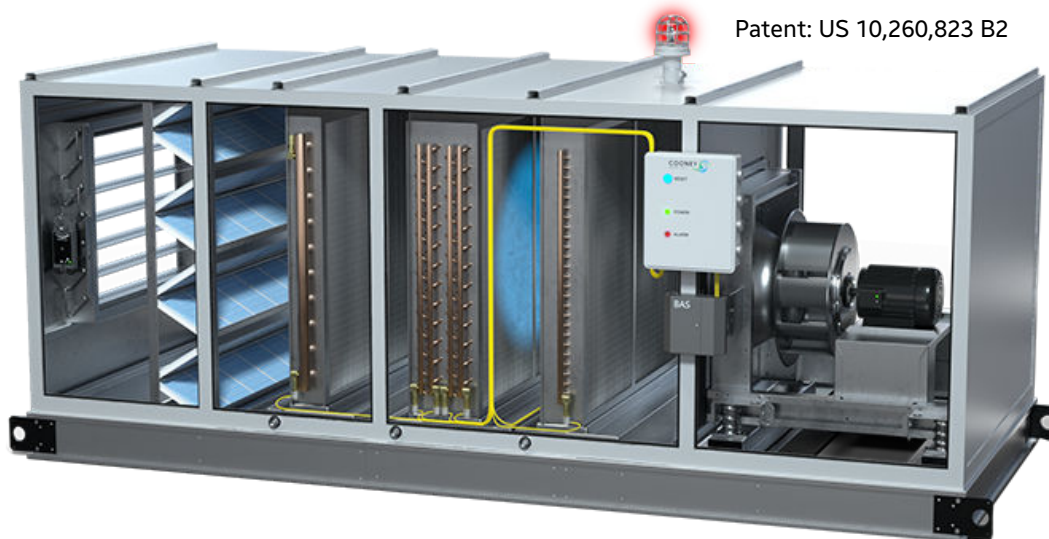

This document details the installation and operation of the Cooney Smart Coil System.

The scope of this document is to provide sufficient details for successful installation of the unit in new installation and to offer operational understanding of the main systems and features of the unit.

**Version 1.8**





# TABLE OF CONTENTS

<b>Introduction</b> .....	<b>2</b>
<b>Quick Start</b> .....	<b>2</b>
General Installation Overview .....	2
<b>Key Components</b> .....	<b>3</b>
Control Box.....	3
Front Panel.....	3
Circuit Board .....	4
Input Wires .....	4
<b>Installation</b> .....	<b>5</b>
Control Box.....	5
Building Management Block .....	5
Sensor Block .....	7
Power Block.....	7
<b>Operation</b> .....	<b>8</b>
Application of Power .....	8
Power Up Indicators .....	8
System Reset .....	8
Sensor Operation.....	8
Zone Fault Indicators.....	8
General Fault Indicator.....	9
BM Alarm State Actuation.....	9
<b>Troubleshooting</b> .....	<b>10</b>
Photo Consultation .....	10
Fuse.....	10
<b>Accessories</b> .....	<b>11</b>
Mounting Hardware .....	11
Required Cooney Freeze Block™ Valves .....	11
Installation of New Valves.....	11
<b>Contact us</b> .....	<b>11</b>

# INTRODUCTION



The Cooney Smart Coil System features a reliable sensing system which works hand in hand with the Cooney Coil Freeze Block™ System valves.

The role of the Cooney Smart Coil System is to monitor up to 30 Freeze Block™ Valves 24/7 and to take Alarm Actions on one or more Protection Events.

In the standard configuration, Alarm Actions are the following:

1. Illuminate the internal LED light specific to zone activated.
2. Illuminate the Front Panel Red Alarm Lamp.
3. Trigger a relay to Building Management systems that indicates an Alarm State.

The front panel and inside of the Cooney Smart Coil System are pictured here.



## QUICK START

### General Installation Overview

1. Locate all Freeze Block™ Valves on the coils
2. Install Clips (figure 1) on to the valves
3. Install Sensors (figure 2) into the clips
4. Mount Control Box (figure 5) in desired location
5. Run Sensor cables from the valve(s) to the box
6. Input sensor leads to control box terminal strips
7. Supply appropriate power to the box
8. Test each sensor for functionality



Figure 1:  
Clip



Figure 2:  
Sensor



Figure 3:  
Sensor  
Installed



Figure 4:  
Valve Mated  
with Clip



Figure 5:  
Control Box



Figure 6:  
Clip + Sensor  
Installed

# KEY COMPONENTS



Important elements of the Cooney Sensing Unit are the:

- Control Box
- Front Panel
- Functional Blocks of the Internal Circuit Board: Front Panel Block, Sensor Block, Power Block, Building Management (BM) Block and Fuse.
- Sensor Leads
- Sensor Labels
- Clips
- Panel Sticker

These elements are summarized in the following section to familiarize the reader and covered in greater detail as explained for association to installation or operation in further sections of this document.

## Control Box

The Control Box enclosure is a left hinged, front lid, snap lock, gray Fiberglass / Polyester NEMA 4 rated 8" wide x 10" tall x 6" deep junction box.

There is a metal mounting backplate with electrically connected metal mounting standoffs for the Circuit Board.

## Front Panel

You can see from Illustration 1, there are three active front panel elements:

1. Blue Reset, which is a press switch.
2. Green Power Indicator lamp.
3. Red Alarm Indicator lamp.



Illustration 1



## Circuit Board

Shown here in illustration 2, the Circuit board is mounted to the metal mounting plate of the Enclosure with four mounting screws and has the following functional blocks.

### **Front Panel Block**

Labeled J2, this 6 connector Screw Terminal block provides connectivity to the Front Panel features as described previously via the Front Panel Wire Bundle.

### **Sensor Block**

The Sensor Block is comprised of 6 Zones, each being a 10 conductor spring tensioned terminal block, labeled (J4 – 9) which accept up to 5 Signal / Ground pairs for a total of 30 inputs from remote sensors.

### **Power Block**

Depending upon which option is selected, labeled either (J1) - 120VAC or (J10) - 24 VAC input, the power block is a three conductor screw terminal which accepts Line, Neutral and Ground inputs, providing power to the Smart Coil System.

### **Building Management Block**

Interface to a building management automation system is offered with a three conductor screw terminal labeled J3, with a center common, and Normally Open, Normally Closed counterparts.

### **Fuse**

Onboard 12v DC power is protected from the AC input side via the 2A fuse labeled F1.

## Input Wires

To maintain the water-tight and outdoor ratings of the enclosure, all wiring (power, sensor leads and output) enters the Enclosure via waterproof conduit .

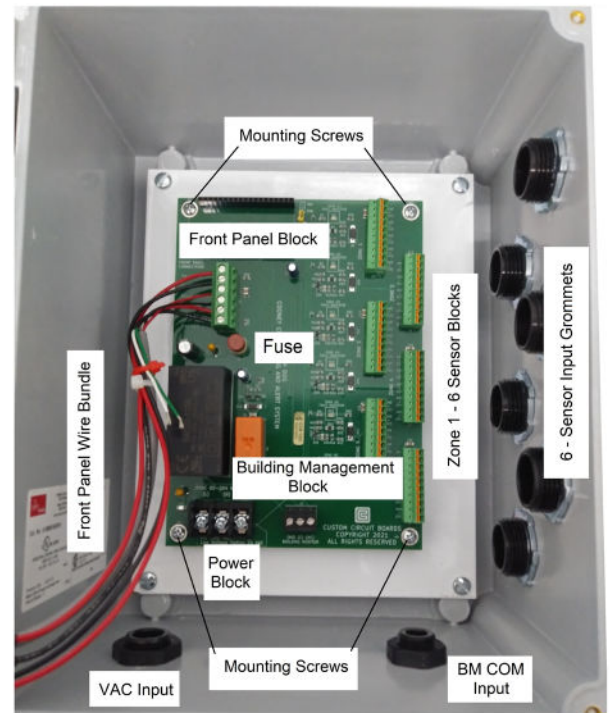

Illustration 2

# INSTALLATION

## Control Box

Mount the control box in an accessible location, either inside or outside of the air handler, using the provided mounting hardware. Illustration 3 shows the proper application of the optional mounting tabs.

Ensure the control box location can be reached by all sensor leads. If you are mounting the control box outside of the air handler, cut a hole in air handler wall to run sensor leads through. The hole size will vary based on the number of leads.

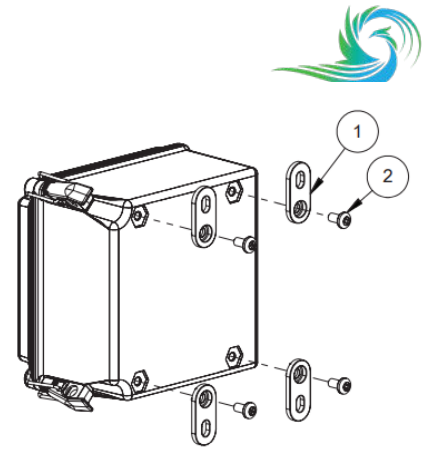

Illustration 3

## Building Management Block

A 3 conductor Screw Terminal Block (J3) is provided for external monitoring. The terminal block is connected to a double pole single throw (DPST) dry contact relay which is actuated by the Alarm State.

Note: This Alarm State indicator is a passive switch and meant for low voltage applications of 48 Volts or less and 4 amps max applied. It is not fused.

As labeled, pins 1 & 2 are Normally Open (NO) and pins 2 & 3 are Normally Closed (NC) during Non-Alarm conditions (no valve deployment).

During an Alarm State, pins 1 & 2 are closed and pins 2 & 3 are open, indicating that one or more valve(s) have deployed. The output will remain in the Alarm State until the fault condition has abated and the reset button is manually pressed.

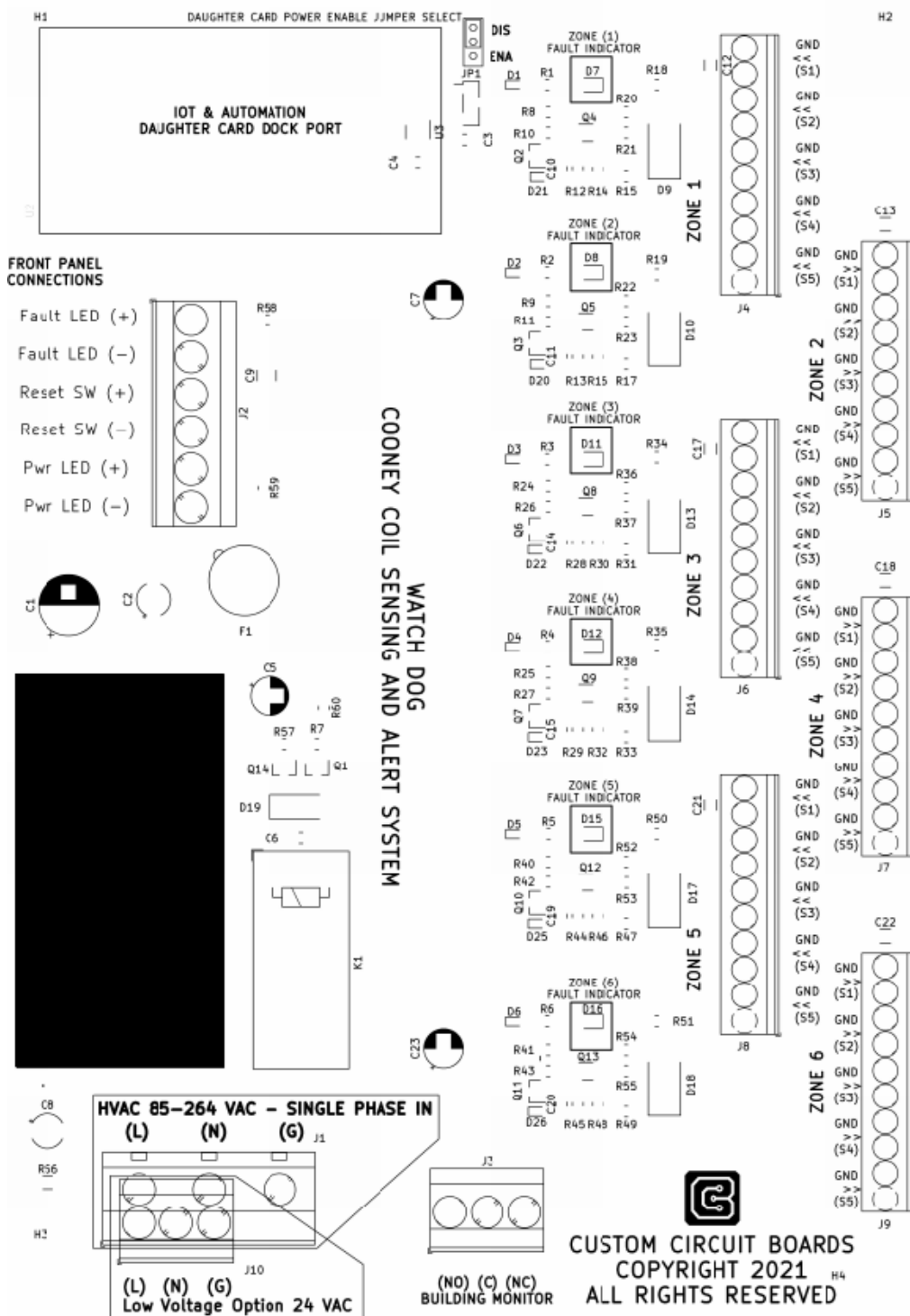

Illustration 4: Circuit Board Diagram

Installation of BM wiring should enter the enclosure and be connected appropriately to the J3 terminal. Loosen the vertical screw of each terminal to allow for conductor placement, and then tighten the screw to compress and secure the wire conductor lead at each port. Do not over tighten the screw terminal. Snug torque is suggested.



# Sensor Block



The sensor block is comprised of six fault detection zones and six associated Terminal Connectors labeled J4, J5, J6, J7, J8, J9 for Zone 1, Zone 2, Zone 3, Zone 4, Zone 5, Zone 6 respectively.

Each Terminal Connector has 10 spring tensioned wire lead inputs that are identified with Signal / Ground Pairs to accommodate up to 5 Sensor Input cable pairs per connector.

You can see from Illustration 4 that markings on the board at each Connector indicate GND >> S(n), to identify the Signal / Ground Pairings.

In this case, both the shield and neutral (white) conductor of the Sensor Cable would be twisted together and installed to the Ground Side of the Sensor / Ground Pair Input.

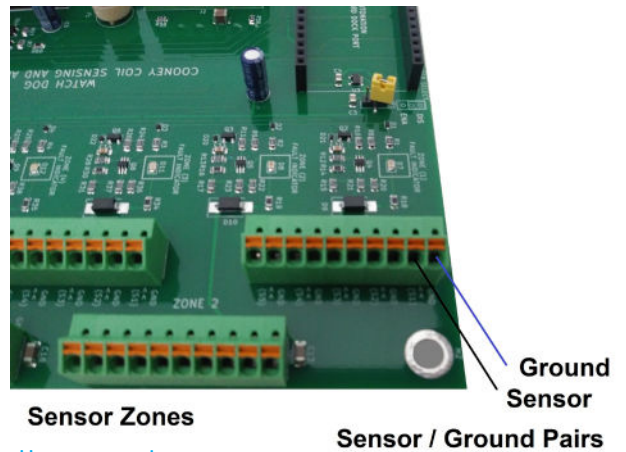

Illustration 5

Sensor conductors are placed into the barrel of each contact input by first depressing the orange spring tension control with a small flat blade screwdriver, insert the conductor lead and release.

# Power Block

There are two power options for the Cooney Smart Coil System: 120VAC and 24VAC. Visually determine which Power Option to be installed and make the appropriate connections. Illustration 6 to the right characterizes the power block for a 24VAC version, as opposed to the 120VAC version shown in illustration 4 above.

For 120VAC function, the J1 connector will be populated with a three-conductor terminal barrier HV block and align to the above: (L) (N) and (G) markings. 24VAC function will populate J10 with a low voltage, three conductor screw terminal block and align to the (L) (N) and (G) markings below.

In either case, first ensure that no power is applied to the supply input lines prior to working with these potentially dangerous conductors.

Connection should be made in all cases with Single Phase AC voltage using three conductor lines of Live, Neutral and Ground. These should be installed to the associated screw terminal marked (L), (N) and (G) respectively.

Loosen the vertical screw of each terminal to allow for conductor placement, and then tighten the screw to compress and secure the wire conductor lead at each port. Do not over tighten the screw terminal. Snug torque is suggested.

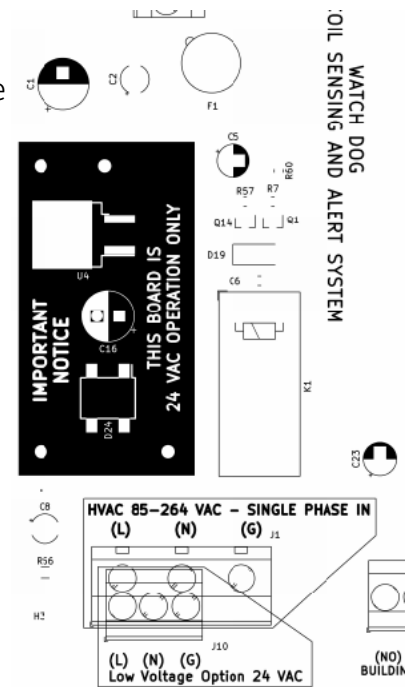

Illustration 6



# OPERATION



For a successful and smooth installation, first make a quick verification of proper connections to the Power Block, Sensor Block, BM Block and insure that the Unit is securely mounted. Following this review, complete the following steps to determine success of the installation.

## Application of Power

At this time, power can be applied from the supply breaker panel.

## Power Up Indicators

Once power is supplied, you should observe the following state:

1. Front Panel Green Power lamp lit.
2. Front Panel Red Alarm lamp lit.
3. Building Management Relay set to Alarm State.
4. Six LED Zone indicators on the PCB are lit.

If this is not the condition, remove power and reassess the connections on the Front Panel Connector, Sensors and VAC.

## System Reset

If the Alarm Lamp is lit, press and release the Front Panel Reset Button once. This should cycle the system to Ready state which is summarized as:

1. Red Front Panel Alarm lamp is no longer lit.
2. Building Management Relay resets to Ready State.
3. Six LED Zone indicators on the PCB are no longer lit.

The system is now in Ready State, or Operational State.

## Sensor Operation

Sensor operation has three tiers of action with Zone Fault indicators, General Fault Indicator and BM Alarm State actuation. All of which should be verified.

## Zone Fault Indicators

On the circuit board, you will note six zone fault indicators which are identified as Zone (1) Fault Indicator to Zone (6) Fault Indicator. These respectively match the six Sensor Blocks and are used to help narrow which zone(s) are at fault. Following system reset, these six indicators should not be illuminated. If one or more is illuminated there is a sensor fault being actively detected on the offending Zone.



## General Fault Indicator

As earlier mentioned, this is the Front Panel Red Lamp, which illuminates to indicate that one or more of the Zone Fault indicators has been triggered and that the system is in an Alarm State. A System Reset should clear this condition, also assuming that no Zones are in fault.

## BM Alarm State Actuation

Finally, the Building Management output indicates the System state by toggling the relay condition which is connected to the BM Terminal Block.

As mentioned, in Ready State, continuity from (NO) to (C) is open circuit and (NC) to (O) is closed circuit.

During Alarm State, this continuity condition flips to indicate to the BM system that an Alarm Condition exists; hence continuity from (NO) to (C) is now closed and (NC) to (O) is now open.

Following a System Reset, Ready and Alarm states can be induced for testing purposes with the following technique.

At one or more sensor inputs, dip the sensor end into a cup of water or squeeze the two leads simultaneously between a wet finger and thumb. This will simulate a Freeze Event / Valve Deployment and latch a fault in the associated Zone.

A latched fault will light the PCB Zone (n) Fault Indicator LED associated with the trip, Light the Red Front Panel Alarm lamp and toggle the Building Management Relay to Alarm State.

A Reset should clear this state and your installation is ready for Operation.

It is suggested to conduct this test cycle on each Sensor line.

# TROUBLESHOOTING



## Photo Consultation

After verifying the connection steps above, if standard operation is not achieved, take a photo of both the Front Panel and inside the enclosure. For the inside shot, be sure and get the back side of the front panel which includes the Front Panel Wire bundle.

With those two photos, make a call to our engineering support at (610) 783-1136 and email the photos to [info@cooneycoil.com](mailto:info@cooneycoil.com).

## Fuse

If it appears there is no power to the Circuit Board, as in the case that power is applied and all seven fault indicators did not light, then it may be valid to check the 12 v dc 2A fuse. If there is a blown fuse, it is best to make a visual inspection to determine cause. When this condition is cured, a new fuse may be reinstalled.

Replacement fuses can be commonly purchased from sources such as Digikey.

Replacement part number:

<b>1</b>	<b>Fuse</b>	<b>2 Amp Fuse</b>	<b>WK4957BK-ND</b>	<b>Littlefuse</b>
----------	-------------	-------------------	--------------------	-------------------



# ACCESSORIES

## Mounting Hardware

Mounting Hardware is provided in a separate package and included for potential wall mounting applications. Illustration 7 shows this accessory for easy identification.



Illustration 7

## Required Cooney Freeze Block™ Valves

Beginning in October 2019, all Cooney Freeze Block™ valves are designed with a groove in the hex portion to accept the clip for the Smart Coil Technology. Older generations of the valve did not have this groove. If the coil was purchased before October 2019 than the valves do not have the groove. To install the Smart Coil Technology, the valves with the groove must be installed as this is required to accept the clip/sensor.



Figure 7:  
New Design  
(includes groove)

## Installation of New Valves

*Removal of existing valves:*

1. Place a wrench on the brass adapter above the valve to hold back the adapter while force is applied to remove the valve.
2. Put a 7/8" crescent wrench or socket on the hex portion at the bottom of the valve
3. Rotate the valve counter-clockwise and remove from the adapter

*Installation of new valves:*

1. Thread the new valve into the adapter by hand first to align threads
2. Tighten valve down with crescent wrench or socket wrench until the valve body meets the adapter. (Note: Do not apply Teflon tape/pipe dope to valve threads and do not torque down the valve)
3. Rotate the valve counter-clockwise and remove from the adapter



Figure 8:  
Previous Design  
(no groove)

## CONTACT US

For additional questions and engineering support contact us:

(610) 783-1136

info@cooneycoil.com

Cooney Engineered Solutions

20130 Valley Forge Circle

King of Prussia, PA | 19406

SCAN TO  
REGISTER SMART  
COIL WARRANTY

